



AVIONICS ENGINEERING SERVICES

A D U

ANNUNCIATOR DIM / TEST UNIT

INSTALLATION MANUAL

DESCRIPTION AND THEORY OF OPERATION

INSTALLATION MANUAL
DESCRIPTION AND THEORY OF OPERATION
ANNUNCIATOR DIM / TEST UNIT
P/N 92-7001-X



AVIONICS ENGINEERING SERVICES INC.
6416 EAST TANQUE VERDE
TUCSON, ARIZONA 85715
PHONE: (520) 886-8520
Website: aeseng.com

TABLE OF CONTENTS

Title Page	2
Table of Contents	3
1.0 General Data	4
2.0 FAA Approval	4 - 5
3.0 Mechanical Description and Aircraft Installation	6
4.0 Power Requirements	6
5.0 Theory of Operation	6
6.0 Description	7 - 8
7.0 Night Lighting Adjustment Procedure	9
8.0 ADU Layout - Top View	10
APPENDIX A	11
Block Diagram / Interconnect P/N 92-7001-1	12
Block Diagram / Interconnect P/N 92-7001-2	13
Block Diagram / Interconnect P/N 92-7001-3	14
Mechanical Layout	15

REVISIONS

IR	Complete Manual	July 30, 1992
REV A	Added - 3 ADU	August 20, 1993
REV B	Added DO - 160C Qualifications	July 11, 1994
REV C	Added Night Lighting Adjustment Procedure Corrected part numbers to single digit dash number. Revised interconnect circuit breaker size to 2 amp.	May 31, 2000

1.0 General Data

The Annunciator Dim / Test Unit (ADU) is designed to provide a dedicated source for annunciator power, dimming and testing. The ADU houses two separate P.C. boards. This allows one unit to supply isolated power sources for both pilot and copilot annunciators. Each channel or P.C. board contains 25 diode isolated test lines, one adjustable power supply for dimming 28VDC logic and one adjustable dimming circuit for ground logic. The ADU is available in three versions. P/N 92-7001-1, P/N 92-7001-2 and P/N 92-7001-3. A detailed description of the unit is provided under item 5.0, Theory of Operation.

2.0 FAA Approval

2.1 Applicable TSO

TSO-C71, Airborne Static ("DC to DC") Electrical Power Converter (For Air Carrier Aircraft).

2.2 Applicable Documents

RTCA Document No. DO-160C December 1989, Environmental Conditions and Test Procedures for Airborne Equipment.

2.2.1 DO-160C Environmental Categories

ENVIRONMENTAL QUALIFICATION FORM

NOMENCLATURE: ANNUNCIATOR DIM / TEST UNIT

TYPE/MODEL/PART NO: 92-7001-X TSO NUMBER: C71

MANUFACTURER: Avionics Engineering Services

ADDRESS: 6416 E. Tanque Verde Tucson, Arizona 85715

The ADU and its associated boards and components are qualified to the following test categories:

CONDITIONS	SECTION	DESCRIPTION
Temperature & Altitude	4.0	Category D2
Low Temperature	4.5.1	(-55 C)
High Temperature	4.5.3	(+70 C)
Altitude	4.6.1	(50,000 feet)
Decompression	4.6.2	(45,000 feet)
Overpressure	4.6.3	(-15,000 feet)
Temperature Variation	5.0	Category A
Humidity	6.0	Category A
Shock	7.0	Operational testing only
Operational	7.2	6g
Crash Safety	7.3	Not Applicable
Vibration	8.0	Category B, Equipment tested without shock mounts, Table 8-1.
Explosion	9.0	Category X, No test required
Waterproofness	10.0	Category X, No test required
Fluids Susceptibility	11.0	Category X, No test required

2.2.1 **DO-160C Environmental Categories (cont..)**

CONDITIONS	SECTION	DESCRIPTION
Sand and Dust	12.0	Category X, No test required
Fungus	13.0	Category X, No test required
Salt Spray	14.0	Category X, No test required
Magnetic Effect	15.0	Category X, No test required
Power Input	16.0	Category B
Voltage Spike Conducted	17.0	Category A
Audio Frequency Conducted Susceptibility	18.0	Category B
Induced Signal Susceptibility	19.0	Category A
Radio Frequency Susceptibility	20.0	Category U
Radio Frequency Emission	21.0	Category A
Lightning Induced Transient Susceptibility	22.0	Category X, No test required
Other Tests		
<p>REMARKS:</p> <p>Testing was conducted at Viking Labs / Honeywell in Tucson, Az for Sections 4, 5, 6, 7, 8. Reference report 92-0003-04 for complete details.</p> <p>Testing was conducted at M'sco Labs, Glendale, California for Sections 16, 17, 18, 19, 20, 21. Reference report 92-0003-05 for complete details.</p>		

3.0 Mechanical Description and Aircraft Installation

The ADU is housed in a 1/4 ATR Dwarf box with a DPX2MA-67P67P-34B-0001 connector. The ADU weight is 2.0 lbs. Aircraft interface connector is DPX2MA-67S67S-33B-0001. The ADU is mounted in a standard 1/4 ATR short mounting tray. Forced air cooling is not required.

4.0 Power Requirements

The ADU requires a 2.0 amp circuit breaker with 28 VDC for each channel, (or circuit board). (2ea)

5.0 Theory of Operation

5.1 P/N 92-7001-1

The -1 ADU houses two identical circuit boards that are independent from each other.

Annunciator output power is supplied from the Annunciator +28VDC circuit breaker through a normally closed relay contact. When Dim mode is selected, annunciator power is routed through a variable power circuit that is capable of supplying +28VDC to +10VDC. It is factory set to +14VDC. Power from this circuit is then routed to seven diode isolated power outputs, each capable of handling 0.4 Amps. Total current draw from this circuit is not to exceed 1.5 Amps at +28VDC.

Each board has 25 diode isolated inputs that are grounded during annunciator test mode.

The ADU is designed so that the Bright / Dim and Test mode functions can be triggered by either +28VDC or ground logic.

Each board also contains a variable ground potential circuit for dimming. During normal operation (bright mode) a ground is supplied through a normally closed relay contact. When Dim mode is selected the ground potential is routed through a variable regulator circuit that is adjustable from +0.0VDC to +18VDC. This circuit is also factory set to +14VDC. Total current draw on this circuit is limited to 0.5 amps at +28.0VDC. There is only one output available from this circuit with no test function or diode isolation.

5.2 P/N 92-7001-2

The -1 and -2 ADU's are identical except, the -2 reserves 5 of the 25 diode isolated inputs on each board for the ground potential circuit. In the test mode, these inputs are clamped to +28.0VDC.

5.3 P/N 92-7001-3

The -3 ADU reserves 9 of the 25 diode isolated inputs on each board for the ground potential circuit. In the test mode, these inputs are clamped to +28.0VDC.

6.0 ADU Description

6.1 92-7001-1

Size -	1/4 ATR Dwarf box
Weight-	2.0 lbs
Connector -	DBX2MA-67P67P-34B-0001
Mating connector -	DPX2MA-67S67S-33B-0001
Power requirements -	2.0 amps at +28.0 VDC per channel. (2 ea)
Isolated inputs -	25 per card dedicated to gnd test circuit. (50 total)
Power output -	<ol style="list-style-type: none">1. One adjustable regulator per card. (+10.0 VDC to +28.0 VDC) Factory set to +14.0VDC2. Seven isolated outputs per card. (14 total)3. Max load per isolated output: 0.4 amps.4. Total maximum output per card: 1.5 amps. (3 amps per unit)5. One adjustable circuit per card to bring ground potential from 0.0 VDC to +18.0 VDC. Factory set to +14.0 VDC

6.2 92-7001-2

Size -	1/4 ATR Dwarf box
Weight-	2.0 lbs
Connector -	DBX2MA-67P67P-34B-0001
Mating connector -	DPX2MA-67S67S-33B-0001
Power requirements -	2.0 amps at +28.0 VDC per channel. (2ea)
Isolated inputs -	<ol style="list-style-type: none">1. 20 per card dedicated to gnd test circuit. (40 total)2. 5 per card dedicated to +28.0 VDC test circuit. (10 total)
Power output -	<ol style="list-style-type: none">1. One adjustable regulator circuit per card. (+10.0 VDC to +28.0 VDC) Factory set to +14.0 VDC2. Seven isolated outputs per card. (14 total)3. Max load per isolated output: 0.4 amps.4. Total maximum output per card: 1.5 amps. (3 amps per unit)5. One adjustable circuit per card to bring ground potential from 0.0VDC to +18.0 VDC. Factory set to +14.0 VDC.

6.0 ADU Description (cont.)

6.3 92-7001-3

Size -	1/4 ATR Dwarf box
Weight-	2.0 lbs
Connector -	DBX2MA-67P67P-34B-0001
Mating connector -	DPX2MA-67S67S-33B-0001
Power requirements -	2.0 amps at +28.0 VDC per channel. (2ea)
Isolated inputs -	<ol style="list-style-type: none">1. 16 per card dedicated to gnd test circuit. (32 total)2. 9 per card dedicated to +28.0 VDC test circuit. (18 total)
Power output -	<ol style="list-style-type: none">1. One adjustable regulator circuit per card. (+10.0 VDC to +28.0 VDC) Factory set to +14.0 VDC2. Seven isolated outputs per card. (14 total)3. Max load per isolated output: 0.4 amps.4. Total maximum output per card: 1.5 amps. (3 amps per unit)5. One adjustable circuit per card to bring ground potential from 0.0VDC to +18.0 VDC. Factory set to +14.0 VDC.

7.0 Cockpit Night Lighting Adjustment Procedure (On aircraft)

In most cases, factory settings of the ADU are suitable for aircraft installation without adjustment. To further balance annunciator color differences for night adaptation, perform the following procedure.

- 7.1 A suitable opaque covering for all cockpit windows is required to simulate night lighting conditions in the cockpit. A dual 67 pin breakout harness or breakout box may be optionally used. No other special test equipment is required for this procedure.
- 7.2 Cover the cockpit windows with an opaque blanket or other suitable light-obstructing material. This step is not necessary if this procedure is accomplished under night conditions with no exterior ambient light present.
- 7.3 Pull the circuit breakers for the annunciator dim unit and remove it from its rack. Remove the cover from the unit and re-install in the rack (or optionally, use an appropriate extender harness or breakout box.) Ensure access to top of board A and B in the dim unit with the unit re-installed for adjustment of R5 on each board. (See diagram on page 10 for details.)
- 7.4 Apply ground power to the aircraft. Set all avionics and electrical equipment to normal operating conditions for night flight simulation and select equipment conditions to illuminate annunciator groups as desired.
- 7.5 Position an observer in the cockpit and close the cockpit door or otherwise isolate the cockpit lighting environment from the cabin. The technician next to the annunciator dim unit shall respond to directions from the cockpit observer for adjustments to the annunciator dim unit.
- 7.6 Set up the cockpit lighting conditions for a simulated night flight. (Panel lighting, overhead lighting, EFIS if installed, Bright/Dim switch to Dim.) Allow 30 minutes for the cockpit observer's eyes to adapt to these conditions. Do not open cockpit door or change lighting intensities during this procedure.
- 7.7 Compare intensities of the annunciators in the various added annunciator assemblies to the basic aircraft annunciation and warning panel assemblies. Select modes as required to illuminate several annunciators for comparison. Adjust board A - R5 in the annunciator dim unit to match intensities between annunciator groups as required. Refer to aircraft modification wiring diagrams to determine which annunciator groups are powered by the dim unit's board A (top plug - ADU). If negative potential dimming is connected, adjust Board A - R6 to match these intensities.
- 7.8 Repeat procedure for Board B (bottom plug of ADU) from section 7.7.
- 7.9 Compare pilot and copilot annunciator intensities to ensure acceptable conditions for various annunciation combinations. Typically, matching any red annunciation and adjusting it's level will bring the other colors (green, amber, blue or white) into a satisfactory balance.
- 7.10 Ensure annunciator test illuminates all legends on pilot and copilot respective panels.
- 7.11 Return the aircraft to daylight conditions and ensure annunciators are adequately illuminated during self test and normal operating conditions.
- 7.12 Pull ADU Circuit breakers. Remove annunciator dim unit from rack or extender harness and replace cover; re-install unit.
- 7.13 Perform self test of annunciator dim unit after re-installation by applying ground power and self-testing the annunciators using the appropriate cockpit switch. Verify annunciators illuminate properly.

8.0 ANNUNCIATOR DIM UNIT LAYOUT (View looking down at top of unit with cover removed)

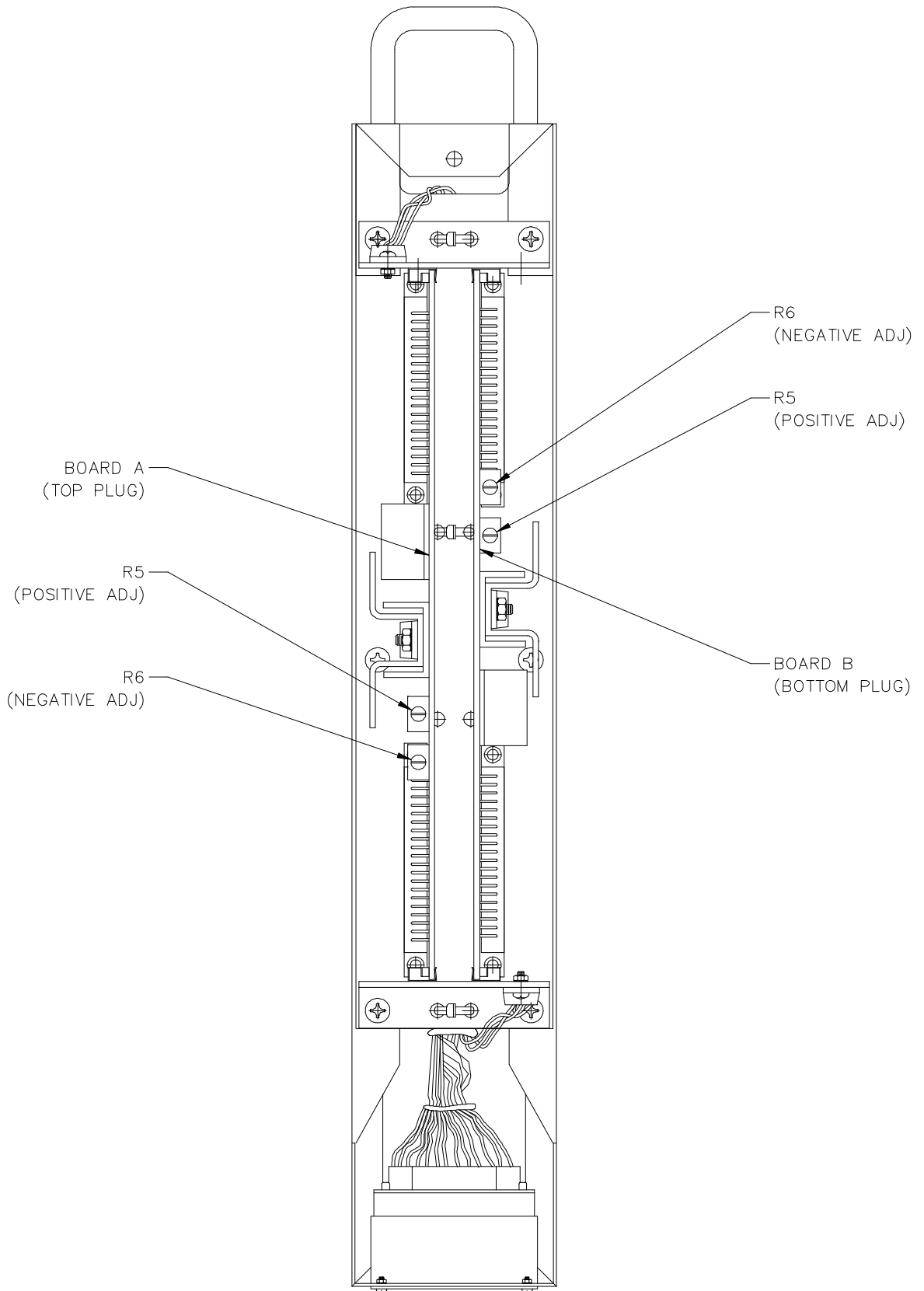

APPENDIX A

ADU BLOCK DIAGRAM / INTERCONNECT P/N 92-7001-1

△ BOTTOM PLUG CIRCUIT IS IDENTICAL TO TOP PLUG.

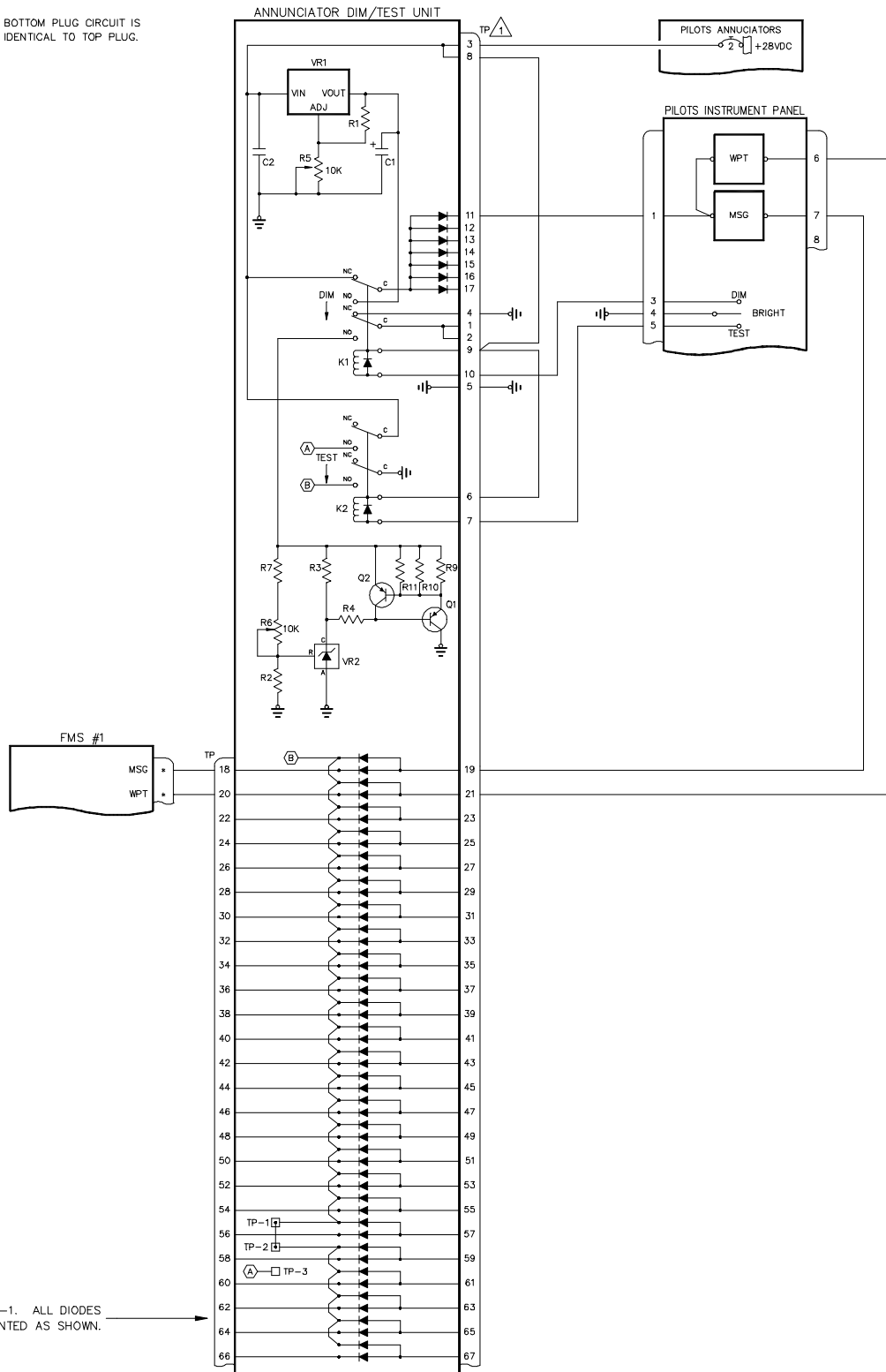

ADU BLOCK DIAGRAM / INTERCONNECT 92-7001-2

⚠ BOTTOM PLUG CIRCUIT IS IDENTICAL TO TOP PLUG.

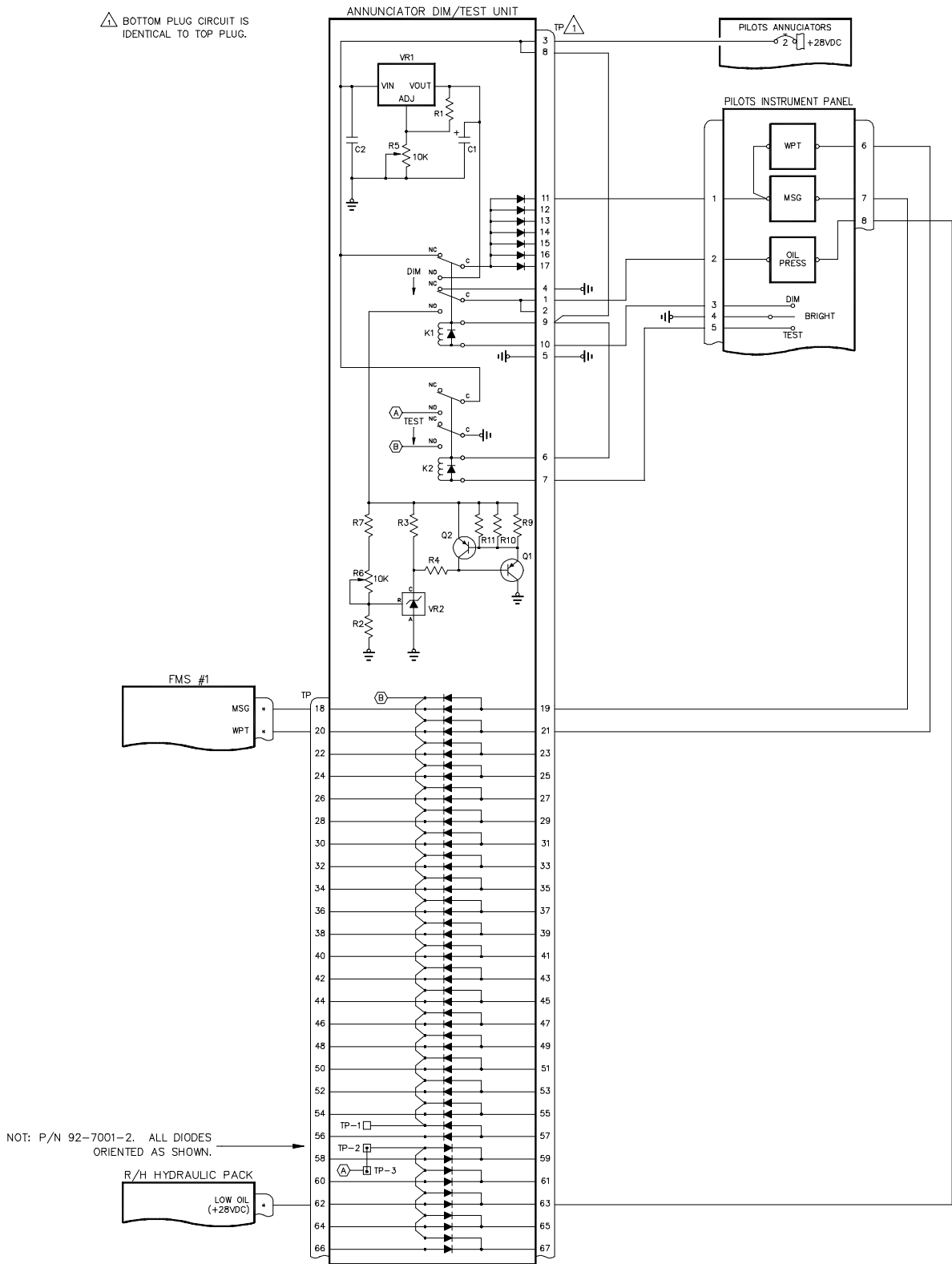

NOT: P/N 92-7001-2. ALL DIODES ORIENTED AS SHOWN.

ADU BLOCK DIAGRAM / INTERCONNECT 92-7001-3

△ BOTTOM PLUG CIRCUIT IS IDENTICAL TO TOP PLUG.

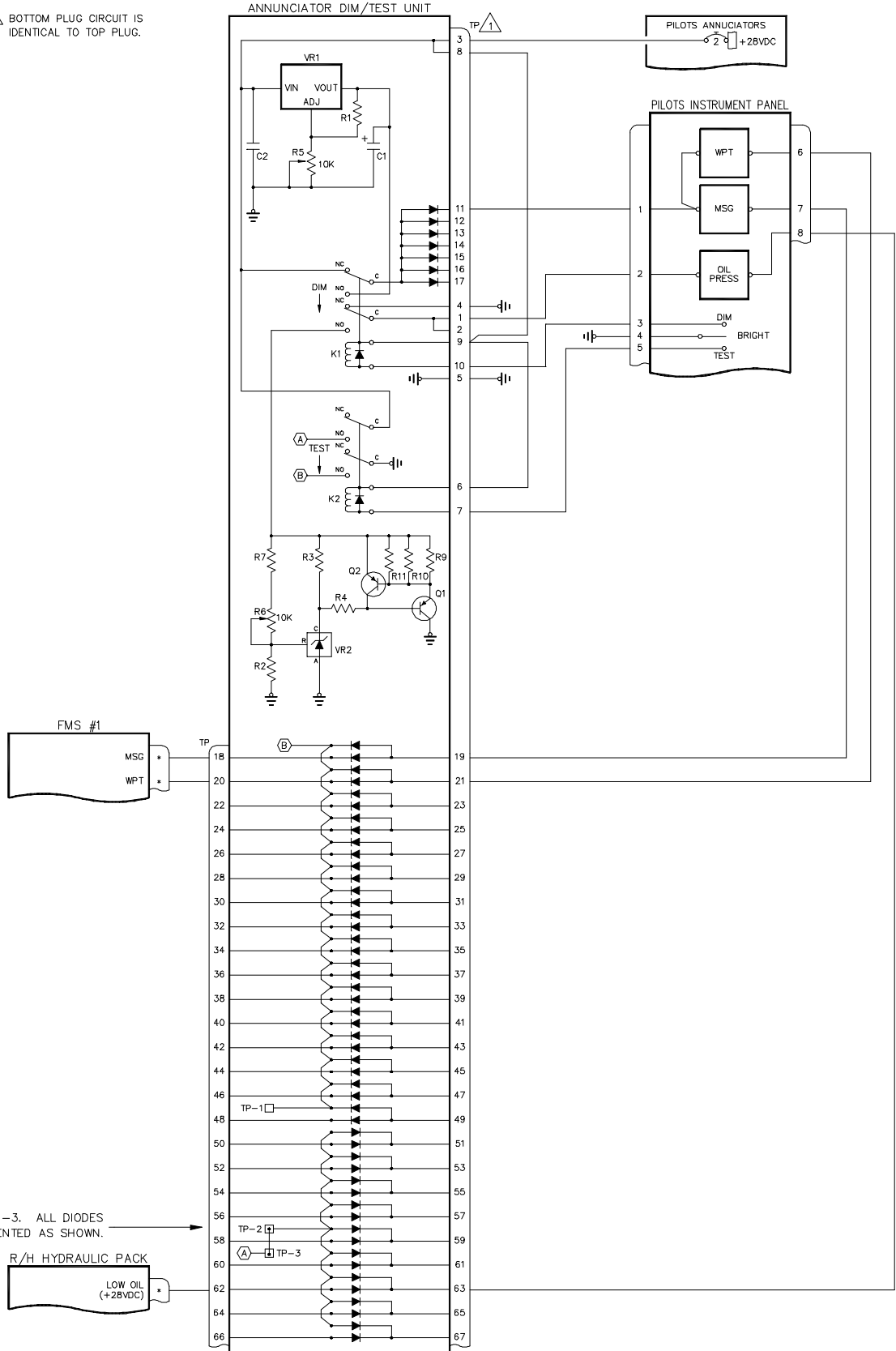

NOT: P/N 92-7001-3. ALL DIODES ORIENTED AS SHOWN.

**ADU
MECHANICAL LAYOUT
P/N 92-7001-X**

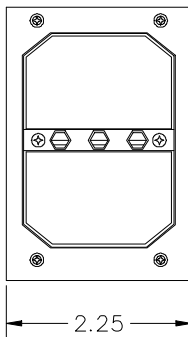
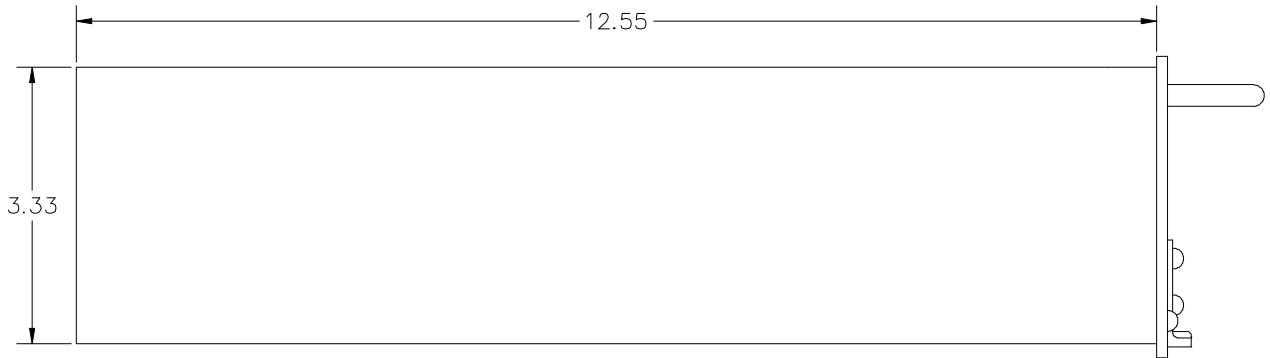

UNIT CONNECTOR:
DPX2MA-67P67P-34B-0001

MATING CONNECTOR:
DPX2MA-67S67S-33B-0001

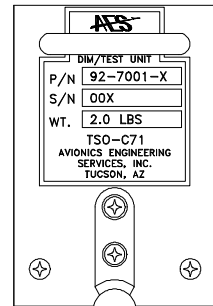

MOUNTING RACK: 1/4 ATR SHORT